



## AV-30-C

# Pilot's Guide



© 2020 - 2023 uAvionix Corporation. All rights reserved.

uAvionix Corporation  
Bigfork, MT

[www.uavionix.com](http://www.uavionix.com)  
[support@uavionix.com](mailto:support@uavionix.com)

Except as expressly provided herein, no part of this guide may be reproduced, transmitted, disseminated, downloaded, or stored in any storage medium, for any purpose without the express written permission of uAvionix. uAvionix grants permissions to download a single copy of this guide onto an electronic storage medium to be viewed for personal use, provided that the complete text of this copyright notice is retained. Unauthorized commercial distribution of this manual or any revision hereto is strictly prohibited.

uAvionix® and Ping® are registered trademarks of uAvionix Corporation and may not be used without express permission of uAvionix.

AV-30, AV-30-E, AV-30-C, AV-Mag, AV-Link, BeaconX, tailBeaconX, and skyBeaconX are trademarks of uAvionix Corporation and may not be used without express permission of uAvionix.

Patents [uavionix.com/patents](http://uavionix.com/patents)

# 1 Revision History

Revision	Date	Comments
A	4/16/2020	Initial release
B	7/13/2020	Added AHRS/ADC startup time. Added clarification on AI/DG toggle function. Clarified power input description, air data connections, GPS interface, low speed arc operation. Modified roll alerts to not specify left or right direction. Clarified AoA description text, alert clearing (mute operation).
C	9/2/2021	Software update 2.1.2. Added Definition of Acronyms & Terms section.
D	12/6/2021	Add transponder control
E	9/29/2022	Corrected DALT to be identified as Density Altitude (was Digital Altitude)
F	3/1/2023	Updated trademarked names list to include AV-Mag and AV-Link. Add AV-Mag directional aiding. "MAG CAL" now used for missing magnetometer calibration. Updated System Interfaces diagrams to include AV-Mag. Updated flight direction indicator description of NO DATA and NO GPS. Add change of DG-ADJ behavior with AV-Mag. Add direct turn section. Updated Table 2. Added Section 13 Stored Data Integrity Check.

## **2 Warnings / Disclaimers**

All device operational procedures must be learned on the ground.

uAvionix is not liable for damages arising from the use or misuse of this product.

This equipment is classified by the United States Department of Commerce's Bureau of Industry and Security (BIS) as Export Control Classification Number (ECCN) 7A994.

These items are controlled by the U.S. Government and authorized for export only to the country of ultimate destination for use by the ultimate consignee or end-user(s) herein identified. They may not be resold, transferred, or otherwise disposed of, to any other country or to any person other than the authorized ultimate consignee or end-user(s), either in their original form or after being incorporated into other items, without first obtaining approval from the U.S. Government or as otherwise authorized by U.S. law and regulations.

### 3 Limited Warranty

uAvionix products are warranted to be free from defects in material and workmanship for two years from the installation of AV-30-C on the aircraft. For the duration of the warranty period, uAvionix, at its sole option, will repair or replace any product which fails in normal use. Such repairs or replacement will be made at no charge to the customer for parts or labor, provided that the customer shall be responsible for any transportation cost.

Restrictions: This warranty does not apply to cosmetic damage, consumable parts, damage caused by accident, abuse, misuse, fire or flood, theft, damage caused by unauthorized servicing, or product that has been modified or altered.

Disclaimer of Warranty: IN NO EVENT, SHALL UAVIONIX BE LIABLE FOR ANY INCIDENTAL, SPECIAL, INDIRECT OR CONSEQUENTIAL DAMAGES, WHETHER RESULTING FROM THE USE, MISUSE, OR INABILITY TO USE THE PRODUCT OR FROM DEFECTS IN THE PRODUCT. SOME STATES DO NOT ALLOW THE EXCLUSION OF INCIDENTAL OR CONSEQUENTIAL DAMAGES, SO THE ABOVE LIMITATIONS MAY NOT APPLY TO YOU.

Warranty Service: Warranty repair service shall be provided directly by uAvionix. Proof of purchase for the product from uAvionix or authorized reseller is required to obtain and better expedite warranty service.

Please email or call uAvionix support with a description of the problem you are experiencing. Also, please provide the model, serial number, shipping address and a daytime contact number.

You will be promptly contacted with further troubleshooting steps or return instructions. It is recommended to use a shipping method with tracking and insurance.

## 4 Table of Contents

1	Revision History .....	3
2	Warnings / Disclaimers.....	4
3	Limited Warranty .....	5
4	Table of Contents .....	6
5	AV-30-C System Information.....	9
5.1	System Description.....	9
5.2	System Functions .....	11
6	Unit Interfaces .....	12
6.1	Aircraft Systems Interfaces.....	12
6.2	Power Input (Required) .....	13
6.3	Pitot and Static Interfaces (Required) .....	14
6.4	GPS Interface (Optional) .....	14
6.5	OAT Probe (Optional).....	14
6.6	Audio Output (Optional).....	15
6.7	Internal Magnetometer (Optional).....	15
6.8	AV-Mag External Magnetometer (Optional).....	15
6.9	Transponder Control (Optional).....	15
7	User Interface.....	16
7.1	Startup and Common Controls .....	16
7.2	“PUSH-SET” Control .....	17
7.3	Direct-Turn .....	18
7.4	User Interface Customization .....	18
7.4.1	AI Mode Customization .....	19
7.4.2	Edit Presented Data.....	20
7.5	AI Mode Display Components .....	21
7.5.1	Basic Components.....	21
7.5.2	Customizable Data Overlay Fields .....	21
7.5.3	Attitude / Slip.....	22

7.5.4	Airspeed Indicator .....	24
7.5.5	Flight Direction Indicator .....	25
7.5.6	Barometric Corrected Altitude Indicator.....	25
7.5.7	AoA Indication.....	27
7.5.8	Vertical Trend Indicator .....	28
7.5.9	G-Load Indicator .....	28
7.5.10	Text Fields .....	29
7.5.11	Accessing Reversionary AI .....	29
7.6	DG Mode Display Components .....	30
7.6.1	DG Mode Customization .....	30
7.6.2	Non-Slaved Heading Mode .....	30
7.6.3	GPS HSI Mode .....	31
7.6.4	GPS ARC Mode.....	31
7.6.5	Operational Aspects.....	32
7.6.6	Accessing Reversionary AI .....	33
7.7	AI / DG Displayable Parameters .....	34
7.8	Reversionary AI.....	35
7.9	Transponder Control.....	36
7.9.1	Status .....	36
7.9.2	Changing Squawk.....	37
7.9.3	Changing Flight ID .....	37
7.9.4	Changing Transponder Mode .....	37
7.9.5	To Send IDENT .....	37
7.9.6	Quick Squawk VFR.....	38
8	User Interface and Font Style Options.....	39
9	Alerts and Alert Limits .....	40
9.1	Altitude Alert .....	41
10	Internal Battery Operation .....	41
10.1	General .....	41

10.2	Battery Transition Logic.....	41
10.2.1	Power-On Self-Test (Pre-Flight).....	41
10.2.2	Power Loss, Airspeed Above 40 Knots (In-Flight).....	43
10.2.3	Power Loss, Airspeed Below 40 Knots (On-Ground).....	43
10.3	Battery Charge Status .....	44
11	AoA Operation and Configuration.....	45
11.1	Operational Methodology.....	45
11.2	Configured Limits.....	46
11.3	Stable Flight Conditions.....	47
11.4	Setting AoA Upper Limit .....	48
11.5	Setting AoA Lower Limit .....	49
11.6	AoA Alert Types and Thresholds .....	50
11.7	Flap Setting Observations .....	50
12	Setup Menu.....	52
12.1	Pilot-Accessible Setup Menu .....	53
12.2	Non-Pilot Accessible Install Menu.....	54
13	Stored Data Integrity Check .....	55
14	Operating Limits & System Specifications .....	55



## 5 AV-30-C System Information

### 5.1 System Description

The uAvionix AV-30-C is a fully digital multi-mode instrument that mounts in the legacy 3-1/8" round instrument panel. It can be field configured as either an Attitude Indicator (AI) or a Directional Gyro (DG) indicator. It is fully self-contained with dual-precision inertial and pressure sensors and allows for a wide variety of pilot customization. Transponder control is available in both AI and DG modes.



Figure 1 - AV-30-C Multi Mode AI/DG/Transponder – Basic Display

When configured as an AI, primary attitude and slip are always displayed. The unused portions of the display area can be customized by the pilot to show a variety of textual and graphical data overlay fields. Three pages may be customized by the pilot while a fourth page presents a fully decluttered view of only attitude and slip, while optionally presenting transponder controls.

When configured as a Directional Gyro (DG), direction of flight information is presented. The flight direction can be configured to be presented as a non-slaved heading, aided by an optional internal magnetometer, or inertially stabilized GPS track when connected to an external GPS navigator. Multiple display presentations, including compass rose, GPS HSI, and GPS Arc views can be selected by the pilot. The unused portions of the display area can similarly be configured for a variety of textual data-overlays.

In AI or DG operating modes, the pilot may select from multiple visual styles which are intended to improve visual compatibility with legacy aircraft instrumentation and preserve the look-and-feel of older aircraft applications.

A wide variety of supplemental functions, including audio alerting, derived angle of attack presentation, G-load display, and more are provided. An internal, rechargeable battery allows for operation for a nominal 1 hour in the event of aircraft power loss and 30 minutes minimum under all operating temperature conditions.

When installed as a non-required instrument (not replacing the existing approved AI or DG), the functional mode of the unit can be toggled between AI and DG by pressing and holding the rotary knob for 3 seconds.

## 5.2 System Functions

### Primary Functions

- Primary Attitude (AI Mode)
- Primary Slip (AI Mode)
- Primary Direction of Flight indication (DG Mode)

### Supplemental Functions

- Indicated Airspeed
- Altitude
- V-Speeds
- Angle of Attack
- Vertical Trend
- Vertical Speed
- Set Altitude
- Heading
- Bus Voltage
- G Load
- Outside Air Temperature
- True Airspeed
- Density Altitude
- GPS Navigator/Waypoint Data
- GPS Navigator Nav Data
- GPS Navigator Route Line
- Heading Bug
- Transponder Control (AI / DG Mode)

### Audio and Visual Alerting Functions

- AoA Alerting
- G Limit Alerting
- Excessive Roll Alerting

### Miscellaneous Functions

- Internal Battery Operation
- Auto/Manual Brightness

## 6 Unit Interfaces

### 6.1 Aircraft Systems Interfaces

The following describes each of the AV-30-C system interconnects for both the AI and DG installation configurations. Various interfaces are optional, and interface to some systems may require additional installation approval.

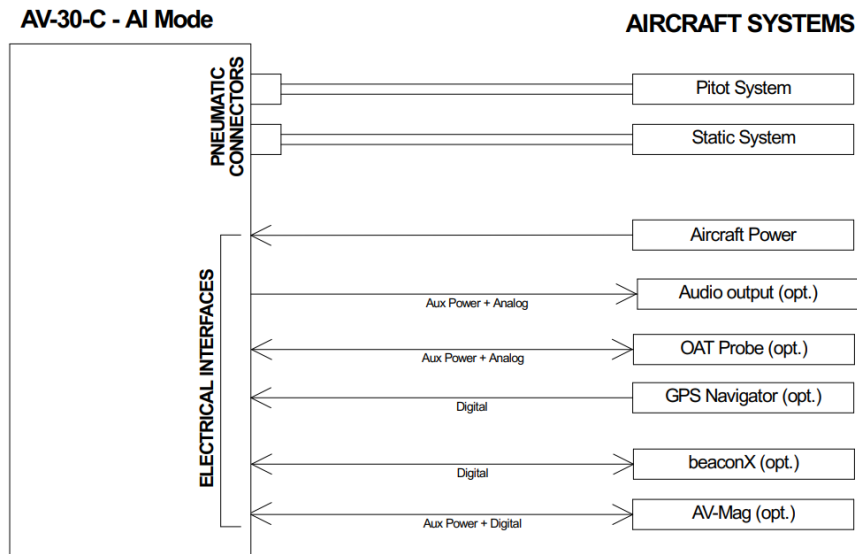

Figure 2 - AV-30-C Aircraft Systems Interfaces - AI Mode

When installed as a DG, no audio outputs are supported, and certain air data parameters are only available when the optional OAT probe is equipped.

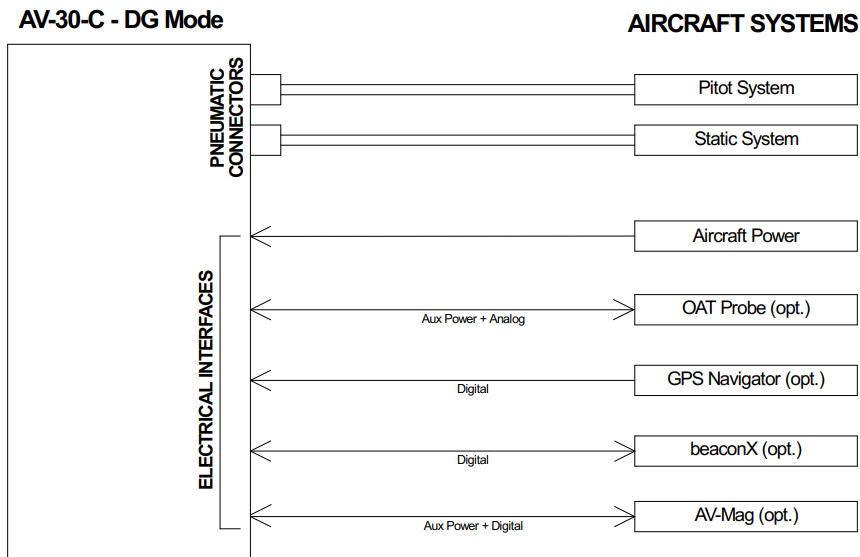

Figure 3 - AV-30-C Aircraft Systems Interfaces - DG Mode

## 6.2 Power Input (Required)

Power input is required in both AI and DG configurations and each unit has a dedicated circuit breaker and internal backup battery. The power input is internally connected, and diode protected with the unit's internal battery via a processor-controlled switch. This architecture allows the unit to continue operation if external power fluctuates or is completely lost.

When external power is supplied to the AV-30-C, there is no mechanism to turn the unit off. When operating on battery, the unit may be forced off with by pressing the left and right buttons until the unit shuts off. See § 10 - *Internal Battery Operation* for more information.

### **6.3 Pitot and Static Interfaces (Required)**

Pitot and static connections are required for AI and DG modes.

Airspeed, altitude, derived angle of attack (AoA), True Airspeed (TAS), Density Altitude (DALT), DG heading, and traffic altitude all require pitot and static connections as they are based on either altitude or airspeed measured from those connections.

### **6.4 GPS Interface (Optional)**

The Global Positioning System (GPS) interface is an optional RS-232 serial input that is compatible with the industry standard aviation output provided by most panel mounted GPS units, and NMEA serial interfaces provided by most hand-held GPS units.

The GPS navigator output is a text/binary protocol that contains situational awareness information such as ground speed, track, distance to destination, cross track, etc., and is typically utilized by remote mapping/display products to provide additional pilot awareness.

This output does not provide IFR compliant lateral or vertical guidance, therefore all GPS track and deviation related data presented is for VFR operations only.

The AV-30-C does no computations or operations on the data obtained from the GPS navigator, and simply displays the received data in a textual or graphical format as configured by the pilot.

### **6.5 OAT Probe (Optional)**

The optional Outside Air Temperature (OAT) probe interface is compatible with the industry standard “Davtron” (C307PS) probe which is mounted external to the aircraft. OAT data is available as a textual data overlay and is used to compute temperature dependent data such as True Airspeed (TAS) and Digital Altitude (DALT). Each AV-30-C requires a dedicated probe. A single OAT probe cannot be shared between multiple units.

The OAT probe is automatically detected by the system, and when present, allows temperature related parameters to be selected for display. If the OAT probe is not detected, display of these parameters is inhibited.

## **6.6 Audio Output (Optional)**

The optional audio output provides audio alerts for the various alerting conditions. This output is typically connected to the aircraft's non-switched audio input on the audio panel. Audio alerting thresholds and alert enablement are configured by the pilot in the Setup Menu.

Audio alerting is only supported when configured as an AI.

## **6.7 Internal Magnetometer (Optional)**

The internal magnetometer, when available, is detected in software version 2.1.1 or later. It is currently disabled by configuration.

## **6.8 AV-Mag External Magnetometer (Optional)**

Support for the AV-Mag external magnetometer is available in software version 2.3.9 or later and requires an AV-Mag to be installed in the aircraft. The AV-Mag provides high quality aiding data to the DG, and requires calibration before use. See §12 and §14 of *AV-30-C Installation Manual UAV-1003947-001* for details on how to calibrate the magnetometer.



The AV-Mag is powered by the AV-30-C. During a power loss, the AV-Mag will be powered by the AV-30-C internal battery and continue to provide aided heading data.

## **6.9 Transponder Control (Optional)**

The AV-30-C has the option of being the control interface for select uAvionix transponders (including the BeaconX family). This provides pressure altitude, mode, squawk code, and IDENT information to the transponder, and displays status and annunciations from the transponder. See section 7.9.



The transponder is not powered by the AV-30-C internal battery. Transponder operations will be unavailable during a power loss.

## 7 User Interface

### 7.1 Startup and Common Controls

The initial power-on splash screen presents the company logo, unit model number, and the currently installed software version.



*Figure 4 – Splash Screen*

Operation in AI and DG modes share the following common user interface controls.





Figure 5 - Common User Interface Components

When installed as a non-required instrument (not replacing the existing approved AI or DG), press and hold the center knob to switch between AI and DG modes when the Function Lock feature is disabled. If the Function Lock feature is enabled, then the pilot may not switch between modes. See *AV-30-C Installation Manual UAV-1003947-001* for configuring the Function Lock feature.

## 7.2 “PUSH-SET” Control

Activate the PUSH-SET window for accessing context menus and settings by momentarily pushing and releasing the main rotary knob.

This activates a window along the bottom of the display to allow various parameters to be adjusted with the rotary knob. Momentarily push and release the knob to scroll through each option.

When you reach the option to change, rotate the knob to scroll through all available values for this option. If the range setting has reached a limit, the left or right indication arrows will indicate which direction the rotary knob will change the setting. Both arrows are visible when the setting can be increased or decreased.

Momentarily push and release the knob to save the updated option value. The settings window will disappear, and the new setting is saved.



The parameters that can be adjusted will vary, based on the mode of the unit and the current configuration of the display. Figure 6 shows how the barometric setting is adjusted when altitude has been configured for display.

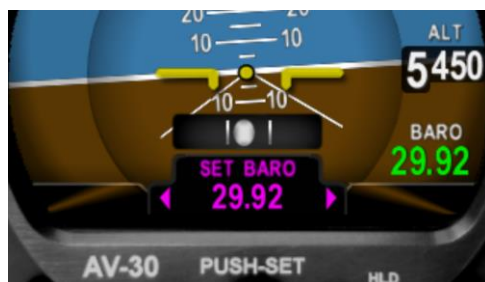

Figure 6 - Push-Set Example – SET BARO

### 7.3 Direct-Turn

Commonly used parameters may be adjusted quickly by simply turning the center knob.

In AI mode, the barometric pressure setting is adjusted by simply turning the knob to bring up the 'SET BARO' window.

In DG mode, the heading bug is adjusted by simply turning the knob to bring up the 'HDG BUG' window.

All adjusted values are active immediately. After adjustment, push and release the center knob to dismiss the window. If after 30 seconds the knob is not pressed, the window will be dismissed automatically.

### 7.4 User Interface Customization

The fourth simplified reversionary page is not configurable and displays minimally required information.



In general, it is suggested that the display be customized prior to flight, and that each page be setup for the different basic modes of flight operations (Departure, En route, Terminal) prior to actual flight operations.

### 7.4.1 AI Mode Customization

Pressing the lower left options MENU button will bring up the first menu, which is the user interface customization menu. In this mode, the cursor can be moved to each customizable area by rotating the rotary knob.



Figure 7 – UI Customization, Menu Entry

The currently selected field will be indicated by a darkened block with a cyan bracket. Rotating the knob left and right will change the currently selected field. To edit the overlay value presented in the currently highlighted field, push the rotary knob.



Figure 8 – UI Customization - Field Selection

A second push of the lower left options MENU button will bring up the second menu. Menu options related to the current screen are displayed.

### 7.4.2 Edit Presented Data

The following shows the display when the edit mode is active. Rotating the knob left and right will then select from the various overlay values that can be presented in the selected field.



When the desired data type is presented, pressing the knob in will accept the current value, and the edit mode will remain active.



Pressing the DONE shown in the lower left button will accept the current value and exit the UI customization mode.



Figure 9 - Display Edit Value

Take note that not all data values can be presented in each editable field area. For example, airspeed will only be displayed on the left main area and altitude will only be displayed on the right side. Additionally, when operating in the DG mode, the available data displayed is different than when operating in the AI mode.

## 7.5 AI Mode Display Components

### 7.5.1 Basic Components

Figure 10 – Basic AI Mode User Interface shows the basic AI with all customizable data overlay fields turned off.

The data shown cannot be disabled or customized:



Figure 10 – Basic AI Mode User Interface

### 7.5.2 Customizable Data Overlay Fields

Figure 11 - AI Mode, Customizable Field Locations shows the locations of the inner and outer customizable fields when operating in the AI mode.

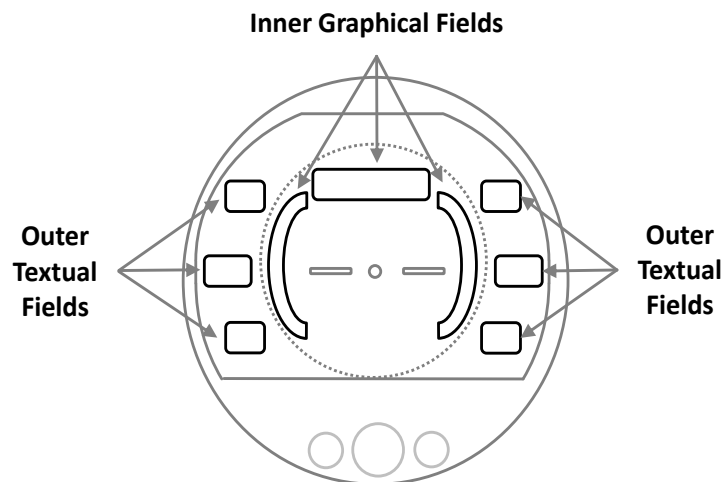

Figure 11 - AI Mode, Customizable Field Locations

There are three independent pages on this screen that may be custom configured as desired by the pilot.

Figure 12 – Data Overlay Examples shows an example of the pilot customizable data overlays (both textual and graphical), located in the non-utilized areas of the display area.



Figure 12 – Data Overlay Examples

When in AI mode, there are three independently customizable pages which are selected round-robin fashion by momentarily pushing and releasing the page selection button repeatedly. The active page is displayed as 1:3, 2:3 and 3:3 on the lower right corner of the display.

A fourth, fully decluttered page allows all supplemental information to be hidden, leaving just attitude and slip displayed. This is accessed by momentarily pushing and releasing the page selection button a fourth time. Return to page 1 by momentarily pushing and releasing the page selection button.

### 7.5.3 Attitude / Slip

The basic display of attitude and slip consists of a traditional attitude indicator display and slip-ball as follows:



Figure 13 - AI Mode, Attitude Indicator

- ➡ On initial startup the red ALIGN flag will flash, indicating that the attitude is still stabilizing.
- ➡ The aircraft should be held as motionless as possible during the alignment process.
- ➡ If power is removed from unit during the alignment phase the unit will remain on battery power until it has aligned.

**When the ALIGN annunciator is displayed, the presented attitude may be incorrect. If ALIGN annunciator does not extinguish after 3 minutes, please contact uAvionix support.**

## 7.5.4 Airspeed Indicator

Indicated airspeed is configured for display on the left side of the screen. The configured units (KTS or MPH) are displayed below the speed value.



Figure 14 – AI Mode, IAS Indicator

The inner arc is a color-coded V-Speed band that rotates to show the configured V-Speed limits against the non-moving white tick mark. The lower arc portion below  $V_{S1}$  provides a red colored slow-speed band that is only displayed when the airspeed has been above  $V_{S1}$  for a given flight. If configured during installation,  $V_{MC}$  and  $V_{YSE}$  appear as red and blue radial tick marks, respectively.

The color of the indicated airspeed numerals will turn yellow when operating in the yellow speed arc, red when operating in a red speed arc, but are otherwise white.



Figure 15 - AI Mode, V-Speed Limits





On initial startup, the airspeed field will display dashes while sensor stabilization occurs.



Airspeed display units and V-Speed limits are configured during installation and are not pilot accessible.

### 7.5.5 Flight Direction Indicator

The upper portion of the AI can be configured to display direction of flight in the form of either non-slaved DG (non-slaved heading), magnetometer aided, or GPS track.

Both modes support a magenta heading bug, and the GPS track mode supports a green bearing-to indicator. The heading bug is not interfaced to the autopilot and is for reference only.

If this field is configured to display GPS track, and no GPS is detected, an amber “NO DATA” will be displayed. If a GPS is detected but it has not achieved a fix or is otherwise not providing useful data, “NO GPS” will be displayed.

If magnetometer aiding is configured but calibration is not complete the “MAG CAL” flag is indicated. If the AV-30-C is not receiving the magnetometer sensor data, the “NO MAG” flag is indicated.

If either the heading bug or the bearing to bug are off the left or right sides of the screen, a colored arrow will show the shortest-turn direction to the corresponding bug. To align the DG bug to current heading, select DG bug, push and hold center rotary knob.



Figure 16 - AI Mode, Direction Indication, Bearing To Off-Screen

### 7.5.6 Barometric Corrected Altitude Indicator

Barometric corrected altitude (BCA) can be configured for display on the right side of the screen and shows the barometric altitude in feet. When

this field is configured for altitude display, the lower right field will be locked to the barometric setting and cannot be modified to display a different parameter.

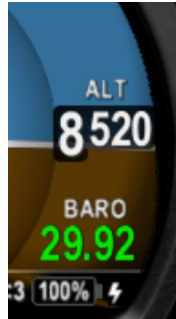



Figure 17 - AI Mode, Altitude Indicator

Adjust the barometric setting utilizing the rotary knob. See §7.2 - “PUSH-SET” Control for additional details.

Barometric setting in inches of Mercury (INHG) or millibars (MB) are selected during installation. It is not a pilot accessible setting.

-  On initial startup, the field will display dashes while sensor stabilization occurs.
-  On unit power-down, the current field elevation and barometric pressure are stored in internal non-volatile memory. On the next power-up, the saved field elevation is used to compute an estimated barometric setting, potentially reducing the required adjustment amount required by the pilot. During this process, the barometric value will be shown in light grey.

## 7.5.7 AoA Indication

Derived Angle of Attack can be configured for display in the inner left area of the screen and consists of a series of colored stacked bars that indicates the current AoA relative to the configured minimum and maximum limits.

The lowest green bar corresponds to a current AoA matching the configured lower limit point. The first red bar corresponds to a current AoA matching the configured upper limit.



AoA limit points are pilot selectable and are set in the pilot accessible Setup Menu.

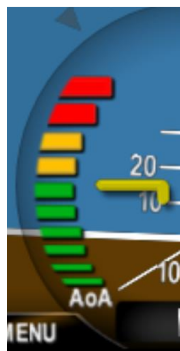

Figure 18 - AI Mode, AoA Indication

AoA is determined by the difference between the aircraft's pitch angle and the path through the air. See §11 - AoA Operation and Configuration for additional details on the AoA operation and setup.

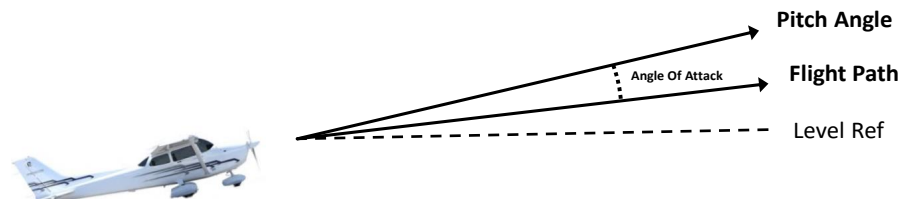

Figure 19 – AoA Computation

## 7.5.8 Vertical Trend Indicator

Vertical trend can be configured for display in the inner right area of the screen and consists of a white tic mark on a background scale. The upper and lower limits of the scale correspond to  $\pm 1000$  feet per minute. This display augments the existing vertical speed in the aircraft but does not replace its functionality.

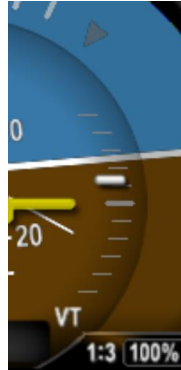

Figure 20 - AI Mode, Vertical Trend Indication

## 7.5.9 G-Load Indicator

The current G-Load can be configured for display on the inner right or left area of the screen and consists of a ball marker on a background scale. The upper and lower limits of the scale correspond to the upper and lower G limits set in the pilot accessible Setup Menu.

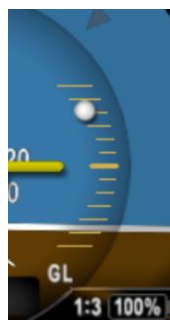

Figure 21 - AI Mode, G-Load Indication

The centermost tick mark represents 1.0 G. Values above the center mark represent positive G, while those below represent less than 1.0 G levels. The scale markers will change color based on G limits set.

See §9 - Alerts and Alert Limits for additional G limit alerting details.

## 7.5.10 Text Fields

The four corners of the display screen can be configured to show various textual parameters. In this example, distance to destination, next waypoint identifier, safety altitude and barometric pressure are displayed.



Figure 22 - AI Mode, Text Fields



If a given parameter is invalid or currently unavailable, it will be presented as a dashed field.



See §7.7 - AI / DG Displayable Parameters for which parameters can be configured for display in these fields.

## 7.5.11 Accessing Reversionary AI

A reversionary style display of attitude and slip is available from the traffic page. Push and release the right button to engage this screen. Push and release the right button again to disengage. When a transponder is interfaced, this page also allows control and monitoring of the transponder as detailed in §7.8 - Reversionary AI. This mode page cannot be customized by the pilot.

## 7.6 DG Mode Display Components

### 7.6.1 DG Mode Customization

The DG customization mode is like the AI customization and the same method is utilized to enter and exit the customization mode.

Editing the upper most field will change the overall direction indication between basic ROSE presentation, GPS HSI presentation, and the GPS ARC presentation.

The individual textual fields may also be selected and customized.

All three pages of the DG may be customized in a similar manner.

### 7.6.2 Non-Slaved Heading Mode

Figure 23 – Basic DG Mode User Interface shows the non-slaved DG heading mode (DG HDG). Six textual fields are available for customization.



Figure 23 – Basic DG Mode User Interface

The external magnetometer (AV-Mag) provides a source of high quality data to aid heading stability. When configured for AV-Mag aiding, long term heading stability will be excellent, but the device is still non-slaved, meaning the user can adjust the DG heading.

### 7.6.3 GPS HSI Mode

The display type can also be configured to show GPS navigation data when connected to an external GPS navigator and presented in the traditional HSI format:



Figure 24 – GPS HSI Mode

### 7.6.4 GPS ARC Mode

The display type can also be configured to show GPS track in an ARC mode, showing a map style presentation of the current waypoint and current navigational leg.



Figure 25 – GPS ARC Mode

Note: The entire programmed flight plan is not displayed, only the current navigation leg and current waypoint.

The display scale is adjusted by rotating the rotary knob and represents the display distance from the ownship icon to the outer compass ring. The following scales may be selected for display:

**Selectable Display Scales:  
1, 2, 5, 10, 20, 50 and 100 N Mi**



All GPS deviation data is limited to VFR operations only, as indicated by the Nav Mode indication (“VFR”).

### **7.6.5 Operational Aspects**

The following applies to operation in DG mode.

- As with the AI mode, three customizable pages can be setup by the pilot. Each page can be configured to show any of the above three display modes.
- Non-Slaved Heading mode requires the pilot to set the initial heading and correct the heading as required based on the compass. The system will initialize to the last set heading on shutdown, except when an AV-Mag external magnetometer is installed. Refer to *AV-30-C Installation Manual UAV-1003947-001* for information regarding the AV-Mag calibration procedure.
- In Non-Slaved Heading Mode, the PUSH-SET menu brings up the DG-ADJ entry on the first push of the rotary knob. However, if an AV-Mag is installed, HDG BUG will appear first and DG-ADJ will be last.
- A pilot entered DG adjustment value can be cleared by entering the PUSH-SET menu, advancing to DG ADJ, then pushing and holding the center knob for 2 seconds. The heading will snap to the value indicated by the AV-Mag and the user entered adjustment will be set to zero. Note that this only applies when the AV-Mag is installed.



- If magnetometer aiding is configured but calibration is not complete the “MAG CAL” flag is indicated. If the AV-30-C is not receiving the magnetometer sensor data, the “NO MAG” flag is indicated.
- GPS HSI and ARC modes are for VFR operations only. No vertical deviations are shown, and lateral deviations are not scaled for approach / IFR operations.
- Air data / temperature related parameters (TAS, DALT, OAT) are only available if the DG has been connected to and OAT probe, otherwise they will not be selectable for display.
- The currently displayed GPS track may optionally be gyroscopically stabilized, allow smoother operation when in turns. This option is configured in the pilot accessible Setup Menu (GPS Track Stabilization).
- When GPS Track is the base direction, any GPS error conditions that might occur are indicated according to Table 1 GPS Error Messages.

Table 1 GPS Error Messages

GPS Error Message	Meaning
NO DATA	No data/messages are being received over the serial port.
NO GPS	No GPS Fix or some other condition is preventing the GPS receiver from providing useful data.
NO COURSE	No waypoint navigation information has been received yet. This message is suppressed when BeaconX is the primary GPS. Displayed on HSI Screen.
NO BEARING	No waypoint navigation information has been received yet. Displayed on ARC Screen.

### 7.6.6 Accessing Reversionary AI

A reversionary style display of attitude and slip is available from the traffic page. Push and release the right button to engage this screen. Push and release the right button again to disengage. When a transponder is

interfaced, this page also allows control and monitoring of the transponder as detailed in §7.8 - Reversionary AI. This mode page cannot be customized by the pilot.

## 7.7 AI / DG Displayable Parameters

The following table shows which data fields can be presented when operating in AI and DG modes.

The presentation type of graphical indicates that the data is presented in a graphical format (dial, tape, bug, etc.), while a presentation type of text indicates that a textual presentation is available.

The OAT field indicates that an OAT probe must be installed for this parameter to be selectable.

The GPS field indicates that a connection to an external GPS navigator is required for the parameter to be selectable.

Table 2 - Data Overlay Types vs Operational Mode

Data Type	Presentation	AI Mode	DG Mode	OAT	GPS
Blank Overlay Field	N/A	✓	✓		
Attitude	Graphical	✓	✓		
Non-Slaved Heading	Graphical	✓	✓		
Bus Voltage	Textual	✓	✓		
G Load Value	Textual	✓	✓		
G Load Indicator	Graphical	✓	✗		
Indicated Airspeed	Textual	✓	✗		
Barometric Corrected Altitude	Textual	✓	✓		
Angle of Attack	Graphical	✓	✗		
Vertical Trend Indicator	Graphical	✓	✗		
Vertical Speed	Textual	✓	✓		
Set Altitude	Textual	✓	✓		

Outside Air Temp	Textual	✓	✓	✓	
True Airspeed	Textual	✓	✓	✓	
Density Altitude	Textual	✓	✓	✓	
Direction Tape	Graphical	✓	x		
Direction Rose	Graphical	x	✓		
Direction Arc	Graphical	x	✓		✓
Direction HSI	Graphical	x	✓		✓
GPS Navigator Data	Textual	✓	✓		✓
GPS HSI Indicator	Graphical	x	✓		✓
GPS Navigator Route	Graphical	x	✓		✓
Heading Bug	Graphical	✓	✓		

## 7.8 Reversionary AI



Figure 26 - Reversionary Attitude Indicator

The fourth page of the AI and DG operating modes presents a reversionary style display of attitude and slip. When a transponder is interfaced, this page also allows control and monitoring of the transponder. This mode page cannot be customized by the pilot, but the transponder control can. See §7.9 - Transponder Control for details on transponder control.

## 7.9 Transponder Control

When installed and configured, the AV-30-C can be used to control select uAvionix transponders (including the BeaconX family). The transponder controls are available on the Reversionary AI page in each mode.

The reversionary AI page is accessed by pressing and releasing the right button repeatedly until AI appears in lower right corner of the display.

### 7.9.1 Status

The transponder control user interface, as presented on the reversionary AI page, is shown below.



A	Configured Callsign / Flight ID
B	Current Squawk Code
C	Mode Selection (STBY, ON, ALT)
D	GPS NIC (integrity metric)
E	GPS NACp (accuracy metric)
F	Pressure Altitude - Green indicates radar interrogation and will change to IDT if IDENT is active
G	Transponder status

Figure 27 - Transponder Control

The current transponder status is indicated by the STAT field. The following status annunciations may be displayed.

Table 3 - Transponder Status

Status	Description
OK	Status good, no fault
NOPOS	No GNSS position information, ensure clear sky view
FAIL	Transponder device failure (broadcast monitor or transmission system)
TMOUT	Timeout, unable to communicate with transponder
MAINT	Maintenance required, ensure proper configuration (e.g. ICAO address)
WAIT	Retrieving configuration from transponder
FAULT	Unknown or generic fault

XPRST	Transponder reset. Maintenance required, ensure proper power connections to tailBeaconX.
-------	--

## 7.9.2 Changing Squawk

- Press and release the center knob
- Navigate highlighted cursor to desired digit by rotating the knob
- Press and release the center knob to select the squawk digit to change
- Rotate the center knob to change the highlighted squawk digit
- Press and release the center knob to accept the changed squawk
- Press and release the left button (*DONE*) to finish and save the setting

## 7.9.3 Changing Flight ID

- Press and release the center knob
- When the Squawk code is displayed, push and hold the center button again until FLIGHT ID appears
- Press and release to enter the first value
- Rotate center knob to change the Flight ID value. When desired value appears, push the center knob to accept the value
- Push and release the right button (CLEAR) at any time to clear the Flight ID completely
- Navigate highlighted cursor to desired character by rotating the knob
- Repeat until the entire Flight ID has been entered
- Press and release the left button (*DONE*) to finish and save the setting



Note: *No spaces are permitted in the FLIGHT ID*

## 7.9.4 Changing Transponder Mode

- Press and release the center knob
- Press and release the right button to cycle through each mode selection (STBY, ON, ALT)
- Press and release the left button (*DONE*) to finish and save the setting

## 7.9.5 To Send IDENT

- Press and release the left button

### 7.9.6 Quick Squawk VFR

BeaconX transponders store a VFR squawk code internally. By default, this is set to 1200 for U.S. operations, but may be changed in the transponder configuration.

In operation, there are two ways to change the squawk code to the default VFR code:

- Press and hold the left button until the VFR squawk code is shown in the SQWK field
- or -
- Press and release the center knob
- Press and release the center knob to select a squawk digit
- Press and release the right button to quick squawk VFR
- Press and release the left button (*DONE*) to finish

## 8 User Interface and Font Style Options

Three different cosmetic styles and two different fonts are selectable by the pilot. The three UI styles are LEGACY, EFIS and VINTAGE. The two font selections are ARIAL and LCD.



Figure 28 - UI Style Options

These settings only effect the displayed colors and font style – all functional operations are identical regardless of style settings.

## 9 Alerts and Alert Limits

There are three alert types

- Excessive Bank Angle Alerts
- Excessive G-Load Limit Alerts
- Excessive Angle of Attack (AoA) Limit Alerts

Figure 29 shows an example how the visual alerts are displayed.



Figure 29 – Example of Alert Annunciator on Screen

The priority and warning / alert levels, from the lowest priority to the highest priority are found in Table 4.

Table 4 - Alert Types and Priorities

Type	Priority	Percent	Aural	Visual
Roll	7	100%	“Roll”	<b>ROLL</b>
AoA	6	80%	One Tone	<b>ANGLE</b>
AoA	5	90%	Two Tones	<b>ANGLE</b>
AoA	4	100%	“Check Angle”	<b>ANGLE</b>
G Limit	3	80%	One Tone	<b>G LIMIT</b>



G Limit	2	90%	Two Tones	<b>G LIMIT</b>
G Limit	1	100%	"G Limit"	<b>G LIMIT</b>

The thresholds for each alert are pilot adjustable, and each alert type can be independently enabled or disabled.



Pressing the rotary knob when an alert is active will clear alert.

## 9.1 Altitude Alert

The Set Altitude alert is a visual alert only. It is signaled by the Set Altitude text display changing from white to green. Green indicates that the barometric corrected altitude is within  $\pm 100'$  of the Set Altitude.

## 10 Internal Battery Operation

### 10.1 General

The internal battery consists of a rechargeable battery system with automatic recharge, self-test, and power switching capability. The internal battery capacity will provide approximately 2 hours of operation at standard temperatures and 30 minutes (minimum) of operational capacity over the operational temperature range.

### 10.2 Battery Transition Logic

The battery is tested, enabled, and disabled based on airspeed and aircraft bus voltage.

#### 10.2.1 Power-On Self-Test (Pre-Flight)

On powerup, the battery charge status will show "TEST" in amber. During this process, an internal load is being applied to the battery to determine general capacity capability. If the battery fails this self-test, the charge status field will show "FAIL" in red, and no battery capability will be available.

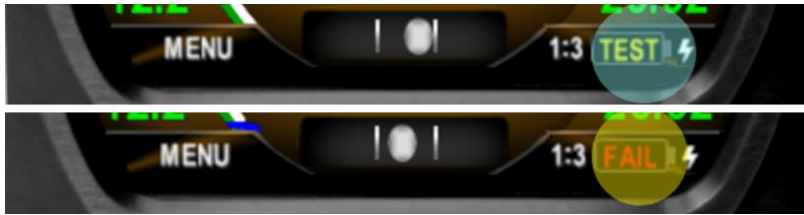

Figure 30- Battery Test Indicators



If the battery status shows “FAIL”, departure into actual or planned IFR conditions must not be performed.

### 10.2.2 Power Loss, Airspeed Above 40 Knots (In-Flight)

When in flight and the bus voltage drops below 7 VDC, the unit will automatically transition to internal battery operation; no pilot action is required for continued operation.

The “ON BATTERY” annunciation will be displayed:



Figure 31 - On Battery Operation

If bus voltage returns, the unit will automatically transition back to aircraft bus power; no pilot action is required. The “ON BATTERY” annunciation will extinguish.

### 10.2.3 Power Loss, Airspeed Below 40 Knots (On-Ground)

When on ground and the bus voltage drops below 7 VDC, the unit will initiate a shut-down sequence. This is the normal “on-ground” shutdown method. Pilot may discontinue the shutdown with any knob or button push.

If bus voltage returns, the shutdown sequence will automatically discontinue, and the unit will return to normal operating mode.

If bus voltage is not returned and the unit remains on, it can be shut down by pressing and holding the left and right buttons until screen goes black.

### 10.3 Battery Charge Status

The battery charge state is shown in percentage from 0 to 100. An internal battery charger will re-charge the battery if bus voltage is above approximately 10 VDC. The battery charge icon (presented adjacent to the battery charge state), will be illuminated during the charge cycle as shown in Figure 32 - Battery Charge Status.



*Figure 32 - Battery Charge Status*

It is normal for the battery charge icon to intermittently flash during the battery charge cycle.

# 11 AoA Operation and Configuration

The following provides a description of how the derived Angle of Attack (AoA) operates and presents the corresponding AoA information to the pilot.

One of the main advantages of an AoA system is that it can provide an early indication of a stall, bringing enhanced awareness to the pilot.

 However, the AV-30-C system is supplemental in nature and does not replace the functionality provided by the aircrafts existing stall warning system.

## 11.1 Operational Methodology

Angle of attack is determined by comparing aircraft pitch to the aircraft flight path angle through the air. In level flight this directly corresponds to the angle at which the wing is intercepting the body of air surrounding the aircraft, with correlates to the current AoA.

Pitch is determined by the precision internal AHRS and flight path angle is determined by air-data based airspeed versus vertical speed measurements.

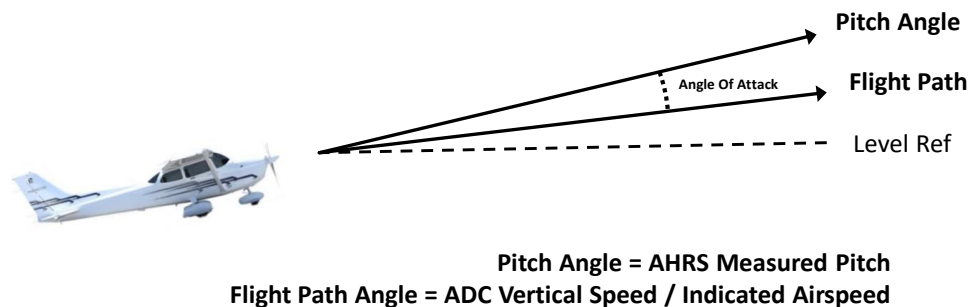

Figure 33 – AoA Computation

As an example of this relationship, during a climb, if the pitch angle is 10 degrees upward, and the aircrafts flight path through the air (forward

airspeed and vertical speed) is also 10 degrees upward, the equivalent AoA is 0 degrees. If, however, the pitch angle is 10 degrees upward, and the aircraft's flight path through the air is only 5 degrees, this corresponds to a positive 5-degree AoA.

A second example is where the pitch is 0 degrees, but the aircraft is descending. The AoA is then equivalent to the descent angle, which will be a negative AoA.

## 11.2 Configured Limits

As each aircraft make and model has different flight characteristics and post-production modifications such as altered wing tips, performance kits and other related modifications may change the flight dynamics of the aircraft, each aircraft has unique configuration limits that must be set for proper AoA operation.

An upper and lower configuration limit is pilot adjustable and provides the scaling mechanism for individual aircraft flight characteristics as it relates to the corresponding AoA display.



The setting of these configuration limits is implemented with a pilot-lockout feature that prevents inadvertent modification.

The upper near-stall configuration limit is set when the aircraft is in the “base-to-final” configuration with flaps and gear set to their normal positions for this maneuver. This provides the best protection when the aircraft is low-and-slow, and the pilot may inadvertently stall based on over-corrections.

- The upper limit is configured to coincide with the aircraft's existing stall warning system and is typically on the order of 10 to 15 degrees. This visually correlates to the first red bar on the AoA display with the second (upper most) red bar providing indication for operation between the aircraft's stall warning and actual stall point.
- A lower limit is configured to coincide with the AoA at which the aircraft flies under normal cruise conditions. This is typically on the order of 3 to 4 degrees. This visually correlates to the lowest one or two green bars on the AoA display.

The figure below shows how the configured upper and lower limits are mapped onto the color coded AoA indication.

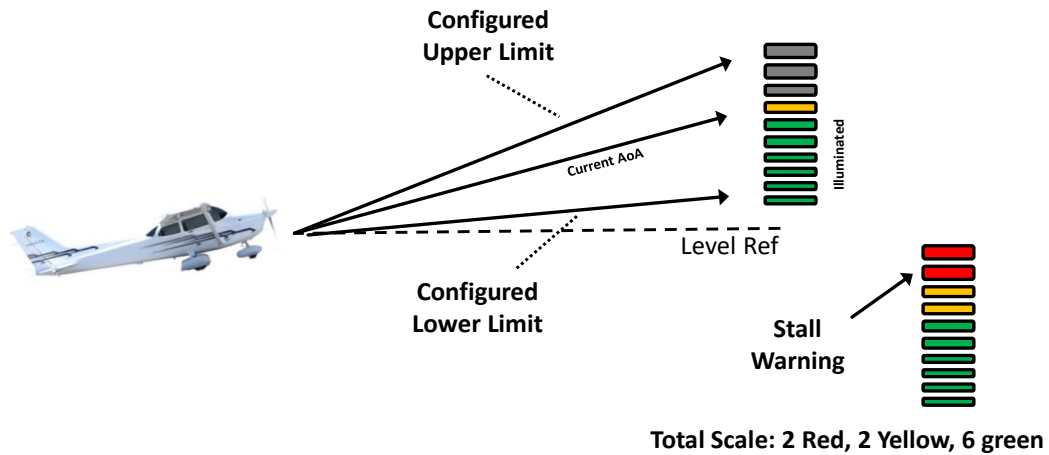

Figure 34 – AoA Upper and Lower Limits

### 11.3 Stable Flight Conditions

Stable flight conditions should be present when determining the upper and lower AoA limits. The in-flight procedures described should be executed when there is minimal turbulence, minimal crosswinds, and the pilot should operate the aircraft as closely as possible to the following:

- Stable power setting
- ± 5° Heading
- ± 5 Knots Airspeed
- ± 50 Feet Altitude
- ± 50 Ft/Min Vertical Speed

Any offsets beyond the parameters above may directly correlate with AoA errors.

## 11.4 Setting AoA Upper Limit

The objective is to set the upper AoA limit such that the first red bar illuminates at roughly the same time as the on-set of the aircraft's stall warning system.

To find the upper limit, the following procedure is recommended:

- Ensure the AV-30-C is in INSTALLATION MODE (see Section 12.1).
- Select a safe altitude suitable for stalls, minimum 1,500 feet AGL.
- Aircraft Configuration:
  - Airspeed  $V_{FE}$  or less
  - Flaps 20°
  - Power as required
  - Stable flight conditions
- Slowly reduce speed at a rate of 1 knot per second and maintain a constant altitude.
- Monitor the displayed AoA as the aircraft's angle of attack increases.
- If the aircraft's stall-warning occurs prior to the indicator reaching the first red bar, the upper AoA limit needs to be numerically lowered to coincide with the aircraft's stall-warning point.
- If the aircraft's stall-warning occurs after the indicator has reached the first red bar, the upper AoA limit needs to be numerically raised to coincide with the aircraft's stall-warning point.
- Utilize the Setup Menu section and associated procedure in this manual to adjust the upper limit as required.
- Repeat the above procedure as needed and to ensure consistency.



## 11.5 Setting AoA Lower Limit

The objective is to set the lower AoA limit such that the first green bar illuminates at roughly  $V_A$  (Gross weight adjusted maneuvering speed).



To find the lower limit, the following procedure is recommended:

- Ensure the AV-30-C is in INSTALLATION MODE (see Section 12.1).
- Select a safe altitude suitable for stalls, minimum 1,500 feet AGL.
- Aircraft Configuration:
  - Airspeed  $V_A$
  - Flaps  $0^\circ$
  - Power as required
  - Stable flight conditions
- Monitor the displayed AoA.
- If no green bars are showing, the lower AoA limit needs to be numerically increased. If more than one green bar is showing, the AoA lower limit needs to be numerically decreased. A fluctuating green bar indicates that the lower AoA limit is acceptable.
- Utilize the Setup Menu section and associated procedure in this manual to adjust the upper limit as required.
- Repeat the above procedure as needed and to ensure consistency.

## 11.6 AoA Alert Types and Thresholds

Angle of attack alerts consist of both aural and visual alerts. Three alert levels are provided and are triggered on how close the current AoA is to the configured upper limit (as a percentage).

Table 5 - AoA Alert Limits

Level	Percent	Aural	Visual
Alert 1	80%	One Tone	
Alert 2	90%	Double Tone	
Alert 3	100%	“Check Angle”	

















When an alert is being generated, pressing any button will mute the alert. AoA alerts can also be completely disabled under the pilot preference settings.

## 11.7 Flap Setting Observations

When the upper AoA limit is configured for the “base-to-final” flap setting, and the lower AoA limit is configured for the normal “cruise” flap configuration, the indicated AoA will vary from this baseline when flaps are configured for other phases of flight. The pilot should document the actual indications provided for the various phases of flight.

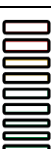
In Table 6, please highlight the actual AoA presentation for the indicated phase of flight.

Table 6 - AoA Observations

Flap Setting	Flaps Up	Flaps Down
Pre-Stall		
Climb Vx		
Climb Vy		
Cruise		
Best Glide Speed		
Approach		
1.3 Vs		
1.2 Vs		
1.1 Vs		

## 12 Setup Menu

The setup menu allows customization of settings that are pilot-accessible. Installer-only related settings are found in *AV-30-C Installation Manual UAV-1003947-001*. Installation settings must be adjusted on the ground.

To access the Setup Menu, push the Menu button twice until the SETUP is shown in the lower window.



Figure 35 – Setup Menu Access

Rotating the knob left and right will access the various parameters that may be configured.



Figure 36 - AOA Alert Setting

Pressing the knob when the desired field is shown will allow the associated setting to be adjusted. After adjustment, pressing the knob again will exit editing mode. Pressing DONE or a lack of user input for 30 seconds will exit the setup menu and return to the primary screen.

## 12.1 Pilot-Accessible Setup Menu

Table 7 contains the options that are available to the pilot for customization of the unit.

Table 7 - Setup Menu Settings

Setting	Description	Options / Setting Range
UI STYLE	Sets Visual Style	LEGACY, EFIS, VINTAGE
UI FONT	Sets Font Style	ARIAL, LCD
AUDIO VOL	Audio Volume for Alerts	0 to 10
AOA ALERT	Enable AoA Alerts	DISABLED, ENABLED
AOA HIGH LIM*	Upper AoA Limit	-28 to +30 (see note below)
AOA LOW LIM*	Lower AoA Limit	-30 to +28 (see note below)
G ALERT	Enable G Load Alert	DISABLED, ENABLED
G POS LIM	Positive G Limit	+2 to +8
G NEG LIM	Negative G Limit	-1 to -8
ROLL ALERT	Enable Roll Alert	DISABLED, ENABLED
ROLL LIM	Roll Alert Threshold	+30 to +80
TRAK STAB	Inertial Track Smoothing	DISABLED, ENABLED
HOURS	Lifetime hours of operation	For reference

\* Note: AoA limits cannot be changed unless the installation menu is enabled. Only enabling or disabling AoA Alerts is permitted when installation menu is disabled. The high and low limit ranges are interdependent.

NOTE: The AoA settings are locked out during normal operation to prevent inadvertent modification.



To access these settings, activate the INSTALLATION MODE by pressing the rotary knob in while initial power is being applied to the unit. See *AV-30-C Installation Manual UAV-1003947-001* for details.

These settings are then available to be modified until the unit's power is cycled.



Also note that in this mode, an additional INSTALL mode menu is available. The pilot should not make any changes to the settings in this menu.

## **12.2 Non-Pilot Accessible Install Menu**

Non-Pilot Accessible settings and options range from air data and attitude trimming, display units and interface options. Contact an authorized facility to access and modify any of these settings.

## 13 Stored Data Integrity Check

Configuration and calibration data stored in non-volatile memory is checked with Cyclic Redundancy Check (CRC) checksums on every power up event. If a data section is found to be corrupted, the user is notified at the power-up splash screen. In some cases, the corrupted values will be set to their defaults. Any additional restoration remedy varies with the type of data. See Table 8 - Integrity Checked Data and Remedies for details.

Table 8 - Integrity Checked Data and Remedies

Message	Data Type and Description	Remedy
"WARNING: OVERLAY reset to defaults. Reconfig required."	Overlay settings. This data is used to determine which fields are active and which data are displayed in those fields.	User to reconfigure overlay fields as per preference or installation log.
"WARNING: CFG reset to defaults. Reconfig required."	Configuration settings. Trim settings, screen selection, AI/DG mode selection, function lock, etc.	Re-set configuration items as per recorded setting in the installation log.
"ERROR: F-CAL value check failure. Verify user calibration data."	Field Calibration. Magnetometer calibration, Altitude trim calibration, pitot-static zero point setting.	Recalibration of the magnetometer if applicable, recalibration of the altitude trim if applicable, and re-zeroing of the pitot-static zero point if applicable.
"ERROR: PROV value check failure. Service required."	Provision settings. These are settings set at the factory.	Contact customer support. Cannot be reconfigured by the user.
"ERROR: Problem with bootloader. Factory service required"	Bootloader software. Software that launches the main software after power-up.	Contact customer support. Cannot be reconfigured by the user.

## 14 Operating Limits & System Specifications

Table 9 - Operating Limits

<b>Operating Limits</b>	
Startup Time	< 3 Minutes
Attitude Rate Limit	±250 degrees per second
Attitude Operational Range	360° Roll, 180° Pitch
Attitude Accuracy	1° Static, 2.5° Dynamic
Airspeed Operational Range	40 to 300 kts
Altitude Operational Range	-1,000 to +25,000 ft
AoA Operational Range	-30° to +30°
AoA Resolution	1°
AoA Valid Speed Range	+35 to +300 kts
AoA Accuracy	2.5°
DALT Operational Range	-1,000 to +25,000 ft
DALT Accuracy	± 500 ft
TAS Operational Range	+35 to +300 kts
TAS Accuracy	± 20 kts
G-Load Operational Range	± 8 g
OAT Operational Range	-40°C to +70°C
OAT Accuracy	±4°C
Bus Voltage Range	7 to 35 V
Bus Voltage Accuracy	±1.0 V